

ingun[®]

Kontaktstifte · Prüfadapter
Test Probes · Test Fixtures

IN DER PRÜFTECHNIK IN TESTING SOLUTIONS
Nr. 1

Zubehör-/Ersatzteile für Prüfadapterausbau *Accessories and Spare Parts for Fixture Customizing*

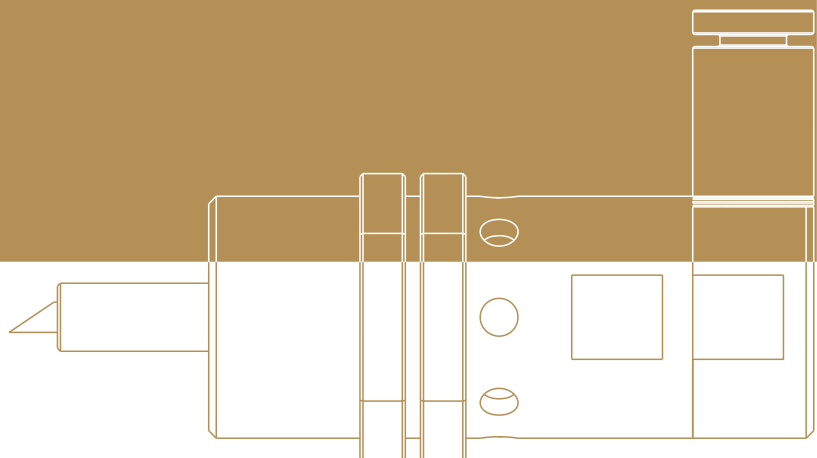

Inhaltsverzeichnis

Table of contents

		Seite
1	Niederhalterstempel	2 - 6
2	Anfahrmechaniken	7 - 8
3	Hauben und Zubehör	9 - 11
4	Mechanische Funktionseinheiten	12 - 15
5	Kleinteile zum prüflingsspezifischen Ausbau	16 - 19
6	Einzelteile zu INGUN-Grundgeräten	20 - 24
7	Sonstiges	25 - 26

		Page
1	Push-rods	2 - 6
2	Manual Connector Approach Mechanisms	7 - 8
3	Covers and Accessories	9 - 11
4	Mechanical Functional Units	12 - 15
5	Small Parts for Fixture customizing	16 - 19
6	Parts for INGUN Base Units	20 - 24
7	Other	25 - 26

Inhaltsverzeichnis

Table of contents

 1. Niederhalterstempel	
1	Niederhalterstempel
2	Niederhalterstempelkappen
3	Niederhalterstempel für Schieber und Reiter

 1. Push-rods	
1	Push-rods
2	Push-rod caps
3	Push-rods for Slides and Riders

Niederhalterstempel Push-rods

Niederhalterstempel D = Ø 2,5 mm starre Ausführung

Artikel	Niederhalterstempel	Länge (Z)
23571	Ø 2,5 mm (natur)	28,0 mm
28785	Ø 2,5 mm (natur)	34,0 mm
23501	Ø 2,5 mm (natur)	35,5 mm
17712	Ø 2,5 mm (natur)	36,4 mm
17714	Ø 2,5 mm (natur)	41,0 mm
26927	Ø 2,5 mm (natur)	50,0 mm
19813	Ø 2,5 mm (natur)	51,0 mm
21188	Ø 2,5 mm (natur)	51,9 mm
17328	Ø 2,5 mm (dunkelblau)	54,4 mm
17327	Ø 2,5 mm (natur)	54,7 mm
17326	Ø 2,5 mm (gold)	55,0 mm
17325	Ø 2,5 mm (schwarz)	55,3 mm
17324	Ø 2,5 mm (grün)	55,6 mm
17323	Ø 2,5 mm (violett)	55,9 mm
17322	Ø 2,5 mm (hellblau)	56,2 mm
17321	Ø 2,5 mm (hellrot)	56,5 mm
21615	Ø 2,5 mm (natur)	60,0 mm
32348	Ø 2,5 mm (natur)	63,0 mm
		Länge (Y)
17340	Niederhalterstempel- kappe Ø 2,5 mm	20,0 mm

Niederhalterstempel D = Ø 2,5 mm starre ESD-Ausführung

Artikel	Niederhalterstempel	Länge (Z)
23504	Ø 2,5 mm (grün)	55,6 mm
		Länge (Y)
23057	Niederhalterstempel- kappe Ø 2,5 mm	20,0 mm

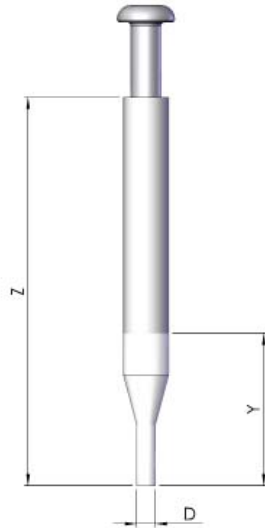

D = Kappendurchmesser (siehe Tabelle)
Y = Kappenlänge (siehe Tabelle)
Z = Gesamtlänge (siehe Tabelle)

D = cap diameter (view table)
Y = pressure pad pushrods cap (view table)
Z = lenght over all (view table)

Push-rods D = Ø 2.5 mm rigid version

Part No.	Push-rods	Length (Z)
23571	Ø 2.5 mm (natural)	28.0 mm
28785	Ø 2.5 mm (natural)	34.0 mm
23501	Ø 2.5 mm (natural)	35.5 mm
17712	Ø 2.5 mm (natural)	36,4 mm
17714	Ø 2.5 mm (natural)	41,0 mm
26927	Ø 2.5 mm (natural)	50.0 mm
19813	Ø 2.5 mm (natural)	51.0 mm
21188	Ø 2.5 mm (natural)	51.9 mm
17328	Ø 2.5 mm (dark blue)	54.4 mm
17327	Ø 2.5 mm (natural)	54.7 mm
17326	Ø 2.5 mm (gold)	55.0 mm
17325	Ø 2.5 mm (black)	55.3 mm
17324	Ø 2.5 mm (green)	55.6 mm
17323	Ø 2.5 mm (violet)	55.9 mm
17322	Ø 2.5 mm (light blue)	56.2 mm
17321	Ø 2.5 mm (light red)	56.5 mm
21615	Ø 2.5 mm (natural)	60.0 mm
32348	Ø 2.5 mm (natural)	63.0 mm
		Length (Y)
17340	Push-rod Cap Ø 2.5 mm	20.0 mm

Push-rods D = Ø 2.5 mm rigid anti-static version

Part No.	Push-rods	Length (Z)
23504	Ø 2.5 mm (green)	55.6 mm
		Length (Y)
23057	Push-rod Cap Ø 2.5 mm	20.0 mm

Niederhalterstempel Push-rods

Niederhalterstempel D = Ø 4,0 mm starre ESD-Ausführung

Artikel	Niederhalterstempel	Länge (Z)
23342	Ø 4,0 mm (grün)	55,6 mm
23190	Ø 4,0 mm (natur)	60,0 mm
23512	Ø 4,0 mm (natur)	63,0 mm
23223	Ø 4,0 mm (natur)	67,0 mm
		Länge (Y)
19315	Niederhalterstempel-kappe Ø 4,0 mm	20,0 mm

Niederhalterstempel D = Ø 6,0 mm starre Ausführung

Artikel	Niederhalterstempel	Länge (Z)
26926	Ø 6,0 mm (natur)	50,0 mm
19815	Ø 6,0 mm (natur)	51,0 mm
21202	Ø 6,0 mm (natur)	51,9 mm
18743	Ø 6,0 mm (gold)	55,0 mm
19419	Ø 6,0 mm (grün)	55,6 mm
21187	Ø 6,0 mm (natur)	56,0 mm
18870	Ø 6,0 mm (natur)	60,0 mm
22241	Ø 6,0 mm (natur)	63,0 mm
22094	Ø 6,0 mm (natur)	67,0 mm
		Länge (Y)
18742	Niederhalterstempel-kappe Ø 6,0 mm	20,0 mm

Niederhalterstempel D = Ø 6,0 mm starre ESD-Ausführung

Artikel	Niederhalterstempel	Länge (Z)
23505	Ø 6,0 mm (grün)	55,6 mm
		Länge (Y)
23503	Niederhalterstempel-kappe Ø 6,0 mm	20,0 mm



Push-rods D = Ø 4.0 mm rigid anti-static version

Part No.	Push-rods	Length (Z)
23342	Ø 4.0 mm (green)	55.6 mm
23190	Ø 4.0 mm (natural)	60.0 mm
23512	Ø 4.0 mm (natural)	63.0 mm
23223	Ø 4.0 mm (natural)	67.0 mm
		Length (Y)
19315	Push-rod Cap Ø 4.0 mm	20.0 mm

Push-rods D = Ø 6.0 mm rigid version

Part No.	Push-rods	Length (Z)
26926	Ø 6.0 mm (natural)	50.0 mm
19815	Ø 6.0 mm (natural)	51.0 mm
21202	Ø 6.0 mm (natural)	51.9 mm
18743	Ø 6.0 mm (gold)	55.0 mm
19419	Ø 6.0 mm (green)	55.6 mm
21187	Ø 6.0 mm (natural)	56.0 mm
18870	Ø 6.0 mm (natural)	60.0 mm
22241	Ø 6.0 mm (natural)	63.0 mm
22094	Ø 6.0 mm (natural)	67.0 mm
		Length (Y)
18742	Push-rod Cap Ø 6.0 mm	20.0 mm

Push-rods D = Ø 6.0 mm rigid anti-static version

Part No.	Push-rods	Length (Z)
23505	Ø 6.0 mm (green)	55.6 mm
		Length (Y)
23503	Push-rod Cap Ø 6.0 mm	20.0 mm

Niederhalterstempelkappen Push-rod Caps

Niederhalterstempelkappen D = Ø 2,5 mm

Artikel	Befestigung	Material	Länge (Y)
17340	aufpressen	Delrin	20 mm
22661	M3	Delrin	20 mm
23057	aufpressen	ESD Material	20 mm
27133	aufpressen	FR4 antistatisch lackiert	20 mm

Niederhalterstempelkappen D = Ø 4,0 mm

Artikel	Befestigung	Material	Länge (Y)
19315	aufpressen	ESD Material	20 mm

Niederhalterstempelkappen D = Ø 6,0 mm

Artikel	Befestigung	Material	Länge (Y)
18742	aufpressen	Delrin	20 mm
23503	aufpressen	ESD Material	20 mm

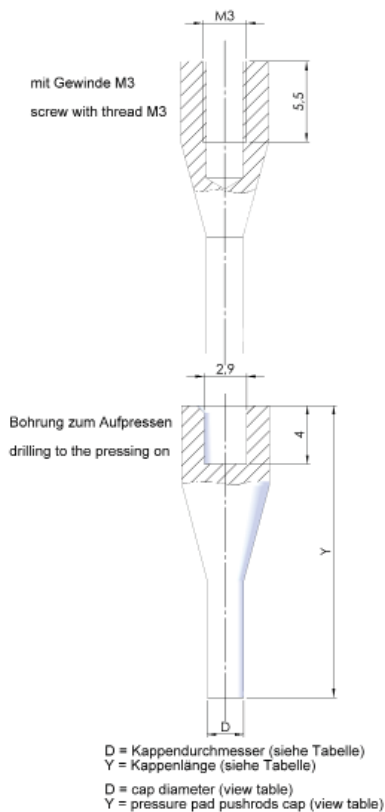

Push-rod Caps D = Ø 2.5 mm

Part No.	Mounting	Material	Length (Y)
17340	press-on	Delrin	20 mm
22661	M3	Delrin	20 mm
23057	press-on	anti-static Material	20 mm
27133	press-on	FR4 anti-static coating	20 mm

Push-rod Caps D = Ø 4.0 mm

Part No.	Mounting	Material	Length (Y)
19315	press-on	anti-static Material	20 mm

Push-rod Caps D = Ø 6.0 mm

Part No.	Mounting	Material	Length (Y)
18742	press-on	Delrin	20 mm
23503	press-on	anti-static Material	20 mm

Niederhalterstempel für Schieber und Reiter *Push-rods for Slides and Riders*

Niederhalterstempel D = Ø 2,5 mm für NDH-Schieber, einstellbare Ausführung

Artikel	Niederhalterstempel	Länge (Z)
17551	Ø 2,5 mm Schieber	34-36 mm
17339	Ø 2,5 mm Schieber	37-40 mm
17338	Ø 2,5 mm Schieber	40-45 mm
17337	Ø 2,5 mm Schieber	45-50 mm
17336	Ø 2,5 mm Schieber	50-60 mm
		Länge (Y)
17340	Niederhalterstempelkappe Ø 2,5 mm	20,0 mm

Niederhalterstempel D = Ø 4,5 mm für NDH-Schieber, einstellbare Ausführung

Artikel	Niederhalterstempel	Länge (Z)
18652	Ø 4,5 mm Schieber	41-45 mm
11642	Ø 4,5 mm Schieber	60-65 mm
		Länge (Y)
3378	Niederhalterstempelkappe Ø 4,5 mm	12,0 mm

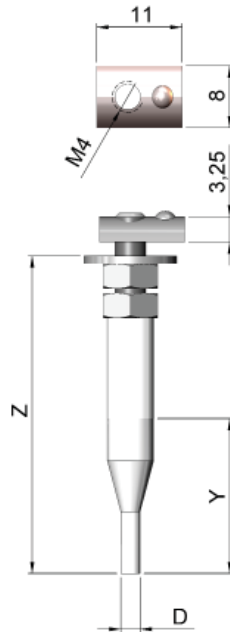

D = Kappendurchmesser (siehe Tabelle)
Y = Kappenlänge (siehe Tabelle)
Z = Gesamtlänge (siehe Tabelle)

D = cap diameter (view table)
Y = pressure pad pushrods cap (view table)
Z = lenght over all (view table)

Push-rods D = Ø 2.5 mm for Pressure Frame Slides, adjustable version

Part No.	Push-rods	Length (Z)
17551	Ø 2.5 mm Slides	34-36 mm
17339	Ø 2.5 mm Slides	37-40 mm
17338	Ø 2.5 mm Slides	40-45 mm
17337	Ø 2.5 mm Slides	45-50 mm
17336	Ø 2.5 mm Slides	50-60 mm
		Length (Y)
17340	Push-rod Cap Ø 2.5 mm	20.0 mm

Push-rods D = Ø 4.5 mm for Pressure Frame Slides, adjustable version

Part No.	Push-rods	Length (Z)
18652	Ø 4.5 mm Slides	41-45 mm
11642	Ø 4.5 mm Slides	60-65 mm
		Length (Y)
3378	Push-rod Cap Ø 4.5 mm	12.0 mm

Inhaltsverzeichnis

Table of contents

 2. Anfahrmechaniken	
1	Manuelle Anfahrmechanik SAM-Mini
2	Manuelle Anfahrmechanik SAM-E Hub 9 (Europaformat)
3	Manuelle Anfahrmechanik SAM-DE Hub 9 (Doppeleuropaformat)
4	Sonderanfahrmekaniken im Europaformat

 2. Manual Connector Approach Mechanism	
1	Manual Connector Approach Mechanism SAM-Mini
2	Manual Connector Approach Mechanism SAM-E Stroke 9 (Single-Euro Format)
3	Manual Connector Approach Mechanism SAM-DE Stroke 9 (Double-Euro Format)
4	Special Connector Approach Mechanisms in Euro Format

Manuelle Anfahrmechanik Manual Connector Approach Mechanism

<p>SAM-Mini</p> <ul style="list-style-type: none"> • Drehwinkel, Betätigung 90° • Hub 10 mm • Hubkraft ca. 30 N • Abmaße: 62 x 37 mm (ohne Hub) 62 x 39,9 mm (ohne Abfrage) <p>Art.-Nr. 31944</p>		<p>SAM-Mini</p> <ul style="list-style-type: none"> • Rotating angle, Activation 90° • Stroke 10 mm • Fixture Contacting Force approx. 30 N • Dimensions: 62 x 37 mm (without stroke) 62 x 39,9 mm (without checking option) <p>Part No. 31944</p>
<p>SAM-E Hub 9 (Europaformat)</p> <ul style="list-style-type: none"> • Drehwinkel, Betätigung 90° • Hub 9 mm • Hubkraft ca. 300 N • Abmaße: 130 x 202 x 84 mm (mit Hebel) <p>Art.-Nr. 1495</p>		<p>SAM-E Stroke 9 (Single-Euro Format)</p> <ul style="list-style-type: none"> • Rotating angle, Activation 90° • Stroke 9 mm • Fixture Contacting Force approx. 300 N • Dimensions: 130 x 202 x 84 mm (with lever) <p>Part No. 1495</p>
<p>SAM-DE Hub 9 (Doppel-Europaformat)</p> <ul style="list-style-type: none"> • Drehwinkel, Betätigung 90° • Hub 9 mm • Hubkraft ca. 300 N • Abmaße: 140 x 268 x 84 mm (mit Hebel) <p>Art.-Nr. 1506</p>		<p>SAM-DE Stroke 9 (Double-Euro Format)</p> <ul style="list-style-type: none"> • Rotating angle, Activation 90° • Stroke 9 mm • Fixture Contacting Force approx. 300 N • Dimensions: 140 x 268 x 84 mm (with lever) <p>Part No. 1506</p>
<p>Sonderanfahrmechaniken im Europaformat</p> <ul style="list-style-type: none"> • Drehwinkel, Betätigung 90° <p>Art.-Nr. 12306 SAM Europaformat 202 x 145 x 84 mm Hub 14 mm Hubkraft 300 N</p> <p>Art.-Nr. 12559 SAM Doppel-Europaf. 268 x 145 x 84 mm Hub 14 mm Hubkraft 300 N</p> <p>Art.-Nr. 9894 SAM Dreifacheuropaf. 420 x 252 x 150 mm Hub 10 mm Hubkraft 400 N</p>		<p>Special Connector Approach Mechanisms in Euro Format</p> <ul style="list-style-type: none"> • Rotating angle, Activation 90° <p>Part No. 12306 SAM Single-Euro Format 202 x 145 x 84 mm Stroke 14 mm Cont. Force 300 N</p> <p>Part No. 12559 SAM Double-Euro Format 268 x 145 x 84 mm Stroke 14 mm Cont. Force 300 N</p> <p>Part No. 9894 SAM Triple-Euro Format 420 x 252 x 150 mm Stroke 10 mm Cont. Force 400 N</p>

Inhaltsverzeichnis

Table of contents

 3. Hauben und Zubehör	
1	Hauben: ESD-Ausführung
2	Gasdruckfedern
3	Befestigung für Gasdruckfedern
4	Lagerbock

 3. Covers and Accessories	
1	Covers: anti-static Version
2	Gas-struts
3	Mounting for Gas Struts
4	Bearing Block

Hauben und Zubehör Covers and Accessories

Hauben: ESD-Ausführung

Artikel	Außenabmaße (X - Y - Z)	Wand- stärke (W)
15533	300 x 215 x 72 mm	12 mm
15534	390 x 360 x 75 mm	15 mm
15535	370 x 220 x 75 mm	15 mm
19252	430 x 360 x 75 mm	15 mm
17023	460 x 215 x 75 mm	15 mm
17261	175 x 404 x 72 mm	12 mm
17469	175 x 245 x 72 mm	12 mm
17560	340 x 390 x 75 mm	15 mm
18394	460 x 390 x 75 mm	15 mm

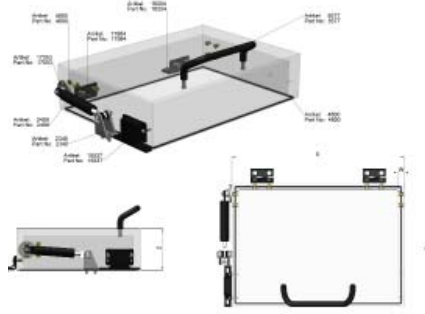

Covers: anti-static Version

Part No.	Overall Sizes (X - Y - Z)	Thick- ness (W)
15533	300 x 215 x 72 mm	12 mm
15534	390 x 360 x 75 mm	15 mm
15535	370 x 220 x 75 mm	15 mm
19252	430 x 360 x 75 mm	15 mm
17023	460 x 215 x 75 mm	15 mm
17261	175 x 404 x 72 mm	12 mm
17469	175 x 245 x 72 mm	12 mm
17560	340 x 390 x 75 mm	15 mm
18394	460 x 390 x 75 mm	15 mm

Hauben und Zubehör Covers and Accessories

Gasdruckfedern

Artikel	Kraft in N	Länge (L) eingefahren	Gesamtlänge (GL) ausgefahren
2499	50	109	145
2504	100	109	145
2497	50	129	185
16548	75	129	185
11536	100	129	185
2500	50	199	305
2501	75	199	305
2502	100	199	305
10770	150	199	305
8078	200	199	305
9991	300	199	305
13200	350	199	305
13201	400	199	305



Gas-struts

Part No.	Force in N	Length (L) retracted	Total Length (GL) extended
2499	50	109	145
2504	100	109	145
2497	50	129	185
16548	75	129	185
11536	100	129	185
2500	50	199	305
2501	75	199	305
2502	100	199	305
10770	150	199	305
8078	200	199	305
9991	300	199	305
13200	350	199	305
13201	400	199	305

Lagerbock

Artikel	Bezeichnung	Abmaße
2348	Lagerbock	siehe Bild

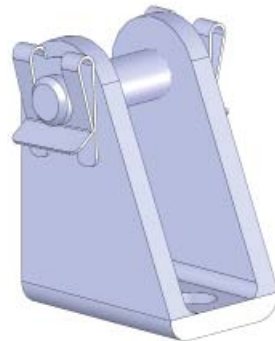

Bearing Block

Part No.	Description	Dimensions
2348	Bearing Block	see photo

Inhaltsverzeichnis

Table of contents

 4. Mechanische Funktionseinheiten	
1	Druckluft-betriebene Markiereinheit
2	Markiereinheit (Lang- und Kurzversion)
3	Absaugvorrichtung für die Markiereinheit
4	Hubmeldekontakt
5	Manuelle Tasterbetätigung
6	Automatischer Schrauber für Potentiometerabgleich
7	Manueller Schrauber für Potentiometerabgleich

 4. Mechanical Functional Units	
1	Pneumatic Marking Unit
2	Extraction Unit for Marking Unit
3	Extraction Unit for Marking Unit
4	Stroke signal contact
5	Manual Tool for operating buttons etc.
6	Automatic Screwing Unit for Potentiometer Adjustment
7	Manual Screwing Unit for Potentiometer Adjustment

Markierung von Leiterplatten Marking of PC Boards

Markiereinheit, elektrisch

- Markiereinheit zur „Gut“-Kennzeichnung
- direkt integrierbar, z.B. auf Kontaktträgerplatte
- Außengewinde M12 x 1
- Kreis Ø 2,0 mm

Art.-Nr. 24447 Stand.-Version m. Ritzer
(Ø 12 x 60 mm)

Art.-Nr. 24456 Lang-Version mit Ritzer
(Ø 12 x 100,5 mm)

Art.-Nr. 27316 Stichel Wechselsatz
(bestehend aus: Gleitlager, Stichel
und Feder)

Art.-Nr. 25251 mit Schneidestichel
(Ø 12 x 60 mm)



Marking Unit, electrical

- Marking Unit used to mark tested „good“
- can be integrated directly on the Probe Plate
- Outside Thread M12 x 1
- Circle Ø 2,0 mm

Part No. 24447 Stand. Version with Engraver
(Ø 12 x 60 mm)

Part No. 24456 Long Version with Engraver
(Ø 12 x 100,5 mm)

Part No. 27316 Engraving Tool Set
(consisting of: Slide Bearing, Engraving
Bit and Spring)

Part No. 25251 with Engraving Bit
(Ø 12 x 60 mm)

Markiereinheit, pneumatisch

- Kompakte, Druckluft betriebene Markiereinheit zur „Gut“-Kennzeichnung
- direkt integrierbar, z.B. auf Kontaktträgerplatte
- Außengewinde M16 x 1
- Kreis Ø 2,0 mm

Art.-Nr. 25241 mit Schneidestichel

Art.-Nr. 29483 mit Kugelstichel



Pneumatic Marking Unit

- Marking Unit used to mark „good“ tested PC Boards powered by means of compressed air
- can be integrated directly on the Probe Plate
- Outside Thread M16 x 1
- Circle Ø 2,0 mm

Part No. 25241 with Engraving Bit

Part No. 29483 with Ball-type Engraving Bit

Absaugvorrichtung für die Markiereinheiten

- die Markiereinheiten werden um einen Trichter mit Absaugschlauch erweitert
- die Späne werden durch einen Pneumatikschlauch einer Kunststoffdose mit Filtereinlage zugeführt und gesammelt
- Absaugung erfolgt über Pneumatik
- Einbaulage variabel gestaltbar

Art.-Nr. 31839



Extraction Unit for Marking Units

- the Marking Units have been enhanced with a funnel and extraction tubing
- the shavings are fed through a pneumatic tubing of a plastic box with filtering system and collected there
- extraction is carried out pneumatically
- assembly position is variable

Part No. 31839

Zubehör Accessories

Hubmeldekontakt

- Mikroschalter mit Drehscheibe
- Aluwinkel zur Befestigung
- Betätigung durch GKS

Art.-Nr. 3308 mit Montagewinkel,
ohne GKS

Art.-Nr. 3408 mit Montagewinkel,
mit GKS

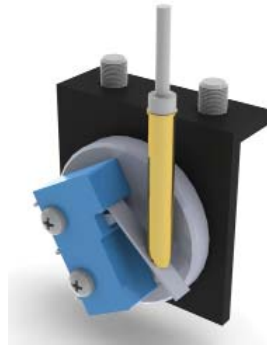

Hubmeldekontakt mit GKS
Stroke signal contact with Probe (GKS)

Stroke signal contact

- Micro switch with adjustment disk
- Aluminium bracket with mounting
- Actuation via Test Probes

Part No. 3308 with assembly bracket,
without Test Probes

Part No. 3408 with assembly bracket,
with Test Probes

Manuelle Tasterbetätigung

- während des prüflingsspezifischen Tests können Taster und Schalter betätigt werden
- Einsatz im Raster 10 mm
- stufenlos einstellbar
- Gesamtlänge: 59 mm
- Größter Durchmesser: 9 mm
- Montagebohrung: M5

Art.-Nr. 19637

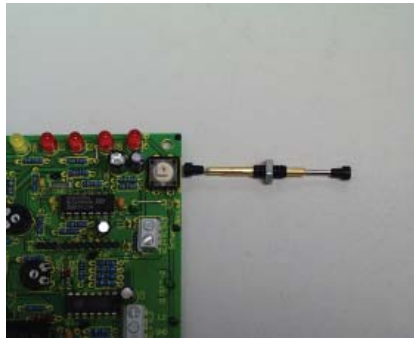

Manual Tool for operating button etc.

- The keys/buttons and switches can be activated during the PCB-specific test
- Usage in a grid of 10 mm (0.4")
- Adjustment position is variable
- Total Length: 59 mm
- Largest diameter: 9 mm
- Assembly hole size: M5

Part No. 19637

Zubehör Accessories

Automatischer Schrauber für Potentiometerabgleich

- Antrieb mittels biegsamer Welle
- Abgleich erfolgt mittels Schrittmotor
- Einsatz im Raster 8 mm

Art.-Nr. 27791 Grundeinheit
 Art.-Nr. 27790 Wechseinheit
 Art.-Nr. 25267 Biegsame Welle
 Ø 1,8 mm
 Art.-Nr. 27780 Kupplung Welle-Motor
 Art.-Nr. 25263 Sensor NPN
 Art.-Nr. 28214 Schrittmotor



Automatic Screwing Unit for Potentiometer Adjustment

- Drive via a flexible shaft
- Adjustment by means of a step-motor
- Usage in 8 mm grid

Part No. 27791 Basic Unit
 Part No. 27790 Interchangeable Unit
 Part No. 25267 Flexible Shaft
 Ø 1.8 mm
 Part No. 27780 Coupling Shaft-Motor
 Part No. 25263 Sensor NPN
 Part No. 28214 Step-Motor

Manueller Schrauber für Potentiometerabgleich

- xxx
- xxx
- xxx

Art.-Nr. xxx xxx

Manual Screwing Unit for Potentiometer Adjustment

- xxx
- xxx
- xxx

Part No. xxx xxx

Inhaltsverzeichnis

Table of contents

 5. Kleinteile zum prüflings-spezifischen Ausbau	
1	Starterkit für MA 21xx
2	Starterkit für MA 160
3	Vorzentrierungen
4	Exzenterstifte
5	Gefederte Fangstifte (Kegel/Dolch)
6	Prüflingsauflagescheiben PAS

 5. Small Parts for Fixture customizing	
1	Start-up Kit for MA 21xx
2	Start-up Kit for MA 160
3	Placement guides
4	Eccentric Pins
5	Spring-loaded Tooling Pins (Cone/Dagger)
6	PCB Support Disks PAS

Kleinteile zum prüflingspezifischen Ausbau *Small parts for Fixture customizing*

Starterkit MA 2109 / 2111 / 2112 / 2113 / 2114

- Art.-Nr. 34730 Starterkit **Small** für bis zu max. 100 Testpunkte
- Art.-Nr. 34731 Starterkit **Medium** für bis zu max. 200 Testpunkte
- Art.-Nr. 34732 Starterkit **Large** für bis zu max. 300 Testpunkte

Bezeichnung	Small (Stück)	Medium (Stück)	Large (Stück)
Niederhalterstempel Art.-Nr. 18870	5	30	15
Niederhalterstempel Art.-Nr. 21615	10	20	30
Vorzentrierung Art.-Nr. 13781	3	3	3
Kreuzschlitzschraube M4x12 Art.-Nr. 2899	3	3	3
Prüflingsauflage Art.-Nr. 3161	15	30	45
Fangstift Ø 4 mm Art.-Nr. 3186	2	2	2
Kontaktsteckhülse KS 1004705	100	200	300
Gefed. Kontaktstift GKS 100-0417	100	200	300

nur als Kit erhältlich (keine Einzelbestellung möglich)



Start-up Kit MA 2109 / 2111 / 2112 / 2113 / 2114

- Part No. 34730 Start-up Kit **Small** for up to max. 100 Test Points
- Part No. 34731 Start-up Kit **Medium** for up to max. 200 Test Points
- Part No. 34732 Start-up Kit **Large** for up to max. 300 Test Points

Description	Small (Piece)	Medium (Piece)	Large (Piece)
Push-rod Part No. 18870	5	30	15
Push-rod Part No. 21615	10	20	30
Pre-centering Part No. 13781	3	3	3
Cross-head Screw M4x12 Part No. 2899	3	3	3
PCB Support Pins Part No. 3161	15	30	45
Tooling Pin Ø 4 mm Part No. 3186	2	2	2
Receptacle KS 1004705	100	200	300
Spring Loaded Test Probe GKS 100-0417	100	200	300

only available as a Kit (no individual ordering possible)

Starterkit für MA 160

- Art.-Nr. 29070 Starterkit für bis zu max. 50 Testpunkten

Artikel-Nr.	Bezeichnung	Stück
3175	Fangstift Ø 2,9 mm	1
3186	Fangstift Ø 4,0 mm	1
22661	Kappe für NDH-Stempel Ø 2,5 mm	10
2962	Schraube FG-Linsenkopf M3x10	10
9286	Unterlegscheibe M3	10
3161	Prüflingsauflage Ø 5,0 mm, antistatisch	10
2517	Exzenterstift M2	4
3021	Sechskantmutter M2,5	4
KS-10030G	Kontaktsteckhülse	50
GKS-100-0100	Gefederter Kontaktstift GKS 100 291 090 A 1500	25
GKS-100-0014	Gefederter Kontaktstift GKS 100 214 150 A 2000	25
3693	Schraube Senkkopf mit Innensechskant M4x10 mm	4
21628	Vorzentrierstift Ø 10 mm	4

nur als Kit erhältlich (keine Einzelbestellung möglich)



Start-up Kit for MA 160

- Part No. 29070 Start-up Kit for up to max. 50 Test Points

Part No.	Description	Piece
3175	Tooling Pin Ø 2.9 mm	1
3186	Tooling Pin Ø 4.0 mm	1
22661	Cap for Push-rods Ø 2.5 mm	10
2962	Rounded head Screw M3x10	10
9286	Washer M3	10
3161	PCB Support Pins Ø 5.0 mm, anti-static	10
2517	Eccentric Pins M2	4
3021	Hexagonal Nut M2.5	4
KS-10030G	Receptacle	50
GKS-100-0100	Spring Loaded Test Probe GKS 100 291 090 A 1500	25
GKS-100-0014	Spring Loaded Test Probe GKS 100 214 150 A 2000	25
3693	Countersunk Screw with Allen screw recess M4x10	4
21628	Placement guides Ø 10 mm	4

only available as a Kit (no individual ordering possible)

Kleinteile zum prüflingspezifischen Ausbau *Small parts for Fixture customizing*

Vorzentrierungen

- zur Führung des Prüflings beim Einlegen
- Befestigungsbohrung M4, Ø 12 mm
- Material Kunststoff
- auch in ESD-Ausführung

Art.-Nr. 13781 (Delrin, 22 mm)
 Art.-Nr. 23056 (sw antistatisch, 22 mm)
 Art.-Nr. 19462 (Delrin, 28 mm)
 Art.-Nr. 20616 (Delrin, 19 mm)



Placement guides

- for guiding the PCB during placement
- Mounting hole M4, Ø 12 mm
- Material Plastic
- also available in anti-static version

Part No. 13781 (Delrin, 22 mm)
 Part No. 23056 (sw anti-static, 22 mm)
 Part No. 19462 (Delrin, 28 mm)
 Part No. 20616 (Delrin, 19 mm)

Exzenterstifte

- zum Fangen und Vorzentrieren von Prüflingen
- einstellbar um die Montagebohrung um 1,3 mm im Radius

Art.-Nr. 2517 Gewinde M2, Länge 38 mm
 Ø 8 mm
 Art.-Nr. 2518 Gewinde M4, Länge 42 mm
 Ø 8 mm
 Art.-Nr. 2519 Gewinde M4, Länge 57 mm
 Ø 8 mm



Eccentric Pins

- for pre-registration and centering of PC-Boards
- adjustable in regard to the assembly hole in 1.3 mm radius

Part No. 2517 Thread M2, Length 38 mm
 Ø 8 mm
 Part No. 2518 Thread M4, Length 42 mm
 Ø 8 mm
 Part No. 2519 Thread M4, Length 57 mm
 Ø 8 mm

Gefederte Fangstifte: Kegel/Dolch

- gefederte Fangstifte für eine bestmögliche Vorzentrierung des Prüflings
- Gesamtlänge: 27 mm
- Maximaler Federweg: 5 mm

Fanglöcher: Ø 2,0 mm bis Ø 3,5 mm
 Art.-Nr. 24481 Kegel
 Art.-Nr. 25214 Dolch

Fanglöcher: Ø 3,5 mm bis Ø 5,5 mm
 Art.-Nr. 25215 Kegel
 Art.-Nr. 25217 Dolch

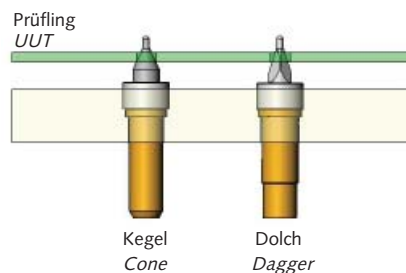

Spring-loaded Tooling Pins: Cone/Dagger

- spring-loaded tooling pins for the best possible pre-registration of the PCB
- Total length: 27 mm
- Maximum stroke: 5 mm

Tooling Pin Holes: Ø 2.0 mm to Ø 3.5 mm
 Part No. 24481 Cone
 Part No. 25214 Dagger

Tooling Pin Holes: Ø 3.5 mm to Ø 5.5 mm
 Part No. 25215 Cone
 Part No. 25217 Dagger

Kleinteile zum prüflingspezifischen Ausbau *Small parts for Fixture customizing*

Prüflingsauflagescheiben PAS

- Prüflingsauflagescheiben mit verschiedenen Kopfdurchmessern und Kopfhöhen
- zur Auflage von Prüflingen
- zum Schutz der Bauteile

PAS mit Zapfen, antistatische Ausführung

Art.-Nr. 3161 Auflage Ø 5,0 mm
Auflagenhöhe 2,8 mm
ESD-Material

Art.-Nr. 17990 Auflage Ø 3,0 mm
Auflagenhöhe 2,8 mm
ESD-Material



Art.-Nr. (Part No.) 3161

PCB Support Disks PAS

- PCB Support Disks with various head-diameters and heights
- for PCB support
- for protection of the components

PAS with gudgeon pin, anti-static version

Part No. 3161 Support Ø 5.0 mm
Support Height 2.8 mm
anti-static Material

Part No. 17990 Support Ø 3.0 mm
Support Height 2.8 mm
anti-static Material

Inhaltsverzeichnis *Table of contents*

 6. Einzelteile zu INGUN-Grundgeräten	
1	Gewindebuchsen
2	Griffe
3	Rundschnur
4	Gegendruckfedern
5	Scharniere
6	Schnappverschlüsse
7	Rastbolzen und Befestigungswinkel
8	Hubzähler

 6. Parts for INGUN Base Units	
1	Threaded Bushes
2	Handles
3	Round sealing cord
4	Counter-pressure Springs
5	Hinges
6	Spring Locks
7	Index Pins and Mounting Brackets
8	Stroke Counters

Einzelteile zu INGUN-Grundgeräten Parts for INGUN Base Units

Gewindebushen

Art.-Nr.	Gewindebuchse (G)	Länge (L)	offen/geschlossen	Material
2384	M4	5	offen	Messing
4890	M4	7,5	geschlossen	Messing
17983	M4	7,5	offen	Messing
2389	M4	9,5	geschlossen	Messing
2386	M4	9,5	offen	Messing

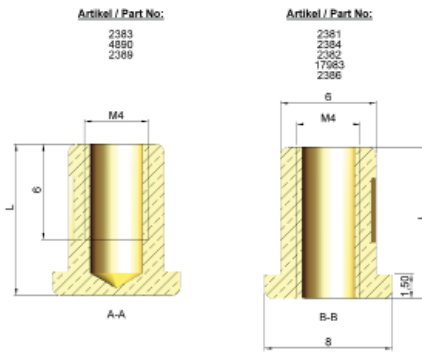

Threaded Bushes

Part No.	Threaded Bushes (G)	Length (L)	open/closed	Material
2384	M4	5	open	Brass
4890	M4	7.5	closed	Brass
17983	M4	7.5	open	Brass
2389	M4	9.5	closed	Brass
2386	M4	9.5	open	Brass

Griffe

Art.-Nr.	Bezeichnung	Material	Bohrungsabstand
21112	Bogengriff	Automatenstahl	128 mm
19057	Messegerätegriff, einklappbar	Stahl verchromt	100 mm
1592	Griffleiste Rahmen	Alu schwarz eloxiert	70 mm
8577	Einschubgriff, abgewinkelt	kunststoffbeschichtet	120 mm
1607	Griff Druckplatte	Alu	89 mm
9442	Griffmulde	Kunststoff	87,6 x 30,7 mm



Art.-Nr. (Part No.) 21112



Art.-Nr. (Part No.) 19057



Art.-Nr. (Part No.) 1592



Art.-Nr. (Part No.) 8577



Art.-Nr. (Part No.) 1607



Art.-Nr. (Part No.) 9442

Handles

Part No.	Description	Material	Hole spacing
21112	Curved Handle	Machining steel	128 mm
19057	Handle for demo unit, retractable	Chrome-plated steel	100 mm
1592	Handle bar	Alu black anodized	70 mm
8577	Push-in handle, angled	Plastic coated	120 mm
1607	Handle for Top Plate	Alu	89 mm
9442	Recessed grip	Plastic	87.6 x 30.7 mm

Einzelteile zu INGUN-Grundgeräten Parts for INGUN Base Units

Rundschnur

Art.-Nr.	Werkstoff	Durchmesser D
5107	Moosgummi	3 mm
5592	Silikon	4 mm
3487	Silikon	4,1 mm
10156	Moosgummi	10 mm

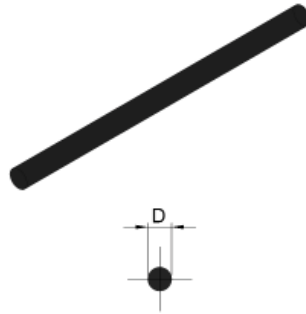

D = Durchmesser (siehe Tabelle)
D = diameter (view table)

Round sealing cord

Part No.	Material	Diameter D
5107	Cellular rubber	3 mm
5592	Silicone	4 mm
3487	Silicone	4.1 mm
10156	Cellular rubber	10 mm

Gegendruckfedern

Art.-Nr.	Durchmesser (D)	Kraft (N)	Länge (Z)	Verwendungszweck
1571	Ø 10 mm	90 N	16 mm	Ausbau
1572	Ø 14 mm	80 N	22 mm	2-Stufen VA 320-420-2
1581	Ø 10 mm	135 N	21,5 mm	2-Stufen-Adapter
1583	Ø 12 mm	12,6 N	23 mm	KTE / ATS *
1584	Ø 11,6 mm	2,6 N	26 mm	KTE / ATS *
2785	Ø 10 mm	80 N	15 mm	Ausbau

* bzw. Prüflingsauflageplatte

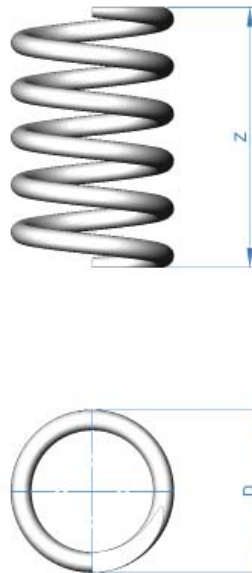

Counter-pressure Springs

Part No.	Diameter (D)	Force (N)	Length (Z)	Usage
1571	Ø 10 mm	90 N	16 mm	Customizing
1572	Ø 14 mm	80 N	22 mm	Dual-stage VA 320-420-2
1581	Ø 10 mm	135 N	21.5 mm	Dual-stage Fixture
1583	Ø 12 mm	12.6 N	23 mm	KTE / ATS *
1584	Ø 11.6 mm	2.6 N	26 mm	KTE / ATS *
2785	Ø 10 mm	80 N	15 mm	Customizing

* respectively PCB Mounting Plate

Einzelteile zu INGUN-Grundgeräten *Parts for INGUN Base Units*

Scharniere

Artikel	Bezeichnung
2281	Anschraub­scharnier Material: Zink-Druckguss, schwarz, Kunststoff beschichtet
3862	Anschraub­scharnier Material: Stahl, schwarz, gepulvert

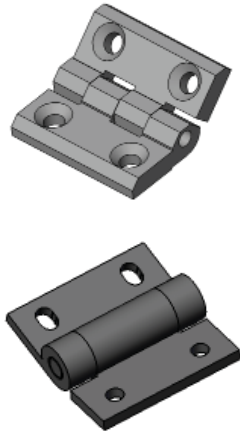

Hinges

Part No.	Description
2281	Screw-in Hinge Material: Zinc die-casting, black, plastic coated
3862	Screw-in Hinge Material: Steel, black, powdered

Einzelteile zu INGUN-Grundgeräten Parts for INGUN Base Units

Rastbolzen

Artikel	Bezeichnung (D)
2511	Rastbolzen mit Kontermutter Gewinde (G): M10 x 1 Gewindelänge (GL): 15 mm Länge (Z): 40 mm
2512	Rastbolzen mit Kontermutter und Rastsperre Gewinde (G): M10 x 1 Gewindelänge (GL): 15 mm Länge (Z): 46 mm



Index Pin

Part No.	Description (D)
2511	Index Pin with counter-nut Thread (G): M10 x 1 Length of Thread (GL): 15 mm Length (Z): 40 mm
2512	Index Pin with counter-nut and Index Catch Thread (G): M10 x 1 Length of Thread (GL): 15 mm Length (Z): 46 mm

Befestigungswinkel

Artikel	Bezeichnung
3069	Befestigungswinkel für Rastbolzen Material: rostfrei Befestigung: M4 Schrauben



Mounting Bracket

Part No.	Description
3069	Mounting bracket for Index Pins Material: rust-free Mounting: M4 Screws

Hubzähler

Art.	Bezeichnung
11224	Hubzähler, incl. Montage Teile <u>Typ:</u> Potentialfreier Eingang Max. Kurzschlussimpedanz: max. 10 kW Restspannung bei geschlossenem Eingang: max. 0,5 V Min. Impedanz Rücksetzeingang Potentialfreier Eingang offen: min 750 kW
35236	Baugruppe, bestehend aus: Kontaktsteckhülsen Schaltkontaktstifte Hubzähler



Stroke Counter

Part No.	Description
11224	Stroke counter, incl. mounting parts <u>Typ:</u> potential-free input Max. Short-circuit Impedance: max. 10 kW Residual voltage by closed input: max. 0.5 V Minimum impedance re-set input Potential-free input open: min 750 kW
35236	PC-Board, consisting of: Receptacles Switching Probes Stroke Counter

Inhaltsverzeichnis *Table of contents*

 7. Sonstiges	
1	Kontaktreinigungsmatte
2	Kontaktierstecker

 7. Other	
1	Contact Cleaning Mats
2	Contact Pins

Kontaktreinigungsmatte *Contact Cleaning Mats*

Reinigung der Tastköpfe mit Kontaktreinigungsmatten

- Für Kopfformen mit selbstreinigenden Eigenschaften (01, 09, 15, 31, 77, 91, 93, 97, 98)
- Kontaktreinigungsmatten sind in allen INGUN Prüfadaptern, welche ohne Niederhalter ausgebaut sind, einsetzbar

Artikel	Bezeichnung	Größe
3254	KRM 01	250 x 100 x 8,5
3255	KRM 02	250 x 200 x 8,5
3256	KRM 03	250 x 300 x 8,5
8460	KRM 04	700 x 500 x 8,5
8363	KRM 05	350 x 350 x 8,5
8369	KRM 05	450 x 450 x 8,5
15984	KRM 07	270 x 350 x 8,5

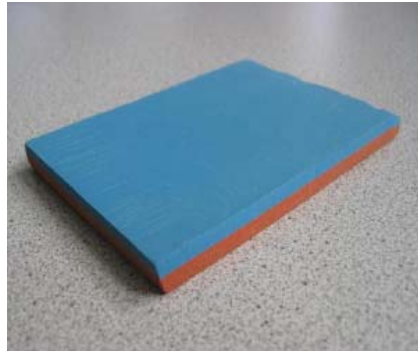

Cleaning the tips of the Probes with Contact Cleaning Mats

- Especially for tip-styles with self-cleaning characteristics (01, 09, 15, 31, 77, 91, 93, 97, 98)
- Contact Cleaning Mats are usable on all INGUN Test Fixtures (except those customized with pressure frames)

Part No.	Description	Size
3254	KRM 01	250 x 100 x 8.5
3255	KRM 02	250 x 200 x 8.5
3256	KRM 03	250 x 300 x 8.5
8460	KRM 04	750 x 750 x 8.5
8363	KRM 05	350 x 350 x 8.5
8369	KRM 05	450 x 450 x 8.5
15984	KRM 07	270 x 350 x 8.5

Kontaktierstecker

- xxx

Vertretungen *Agencies*

Germany

**Baden-Württemberg, Hessen,
Rheinland-Pfalz, Saarland**

Rudi Engelhardt
Bussardstraße 27
D-74889 Sinsheim
Tel. +49 7261 8274
Fax +49 7261 655018
rudi.engelhardt@ingun.com

Bayern

INGUN Prüfmittelbau GmbH
Vertriebsbüro Bayern
Gerhard Raß
Heimdallstraße 7
81739 München
Tel. +49 89 60013662
Fax +49 89 60019605
gerhard.rass@ingun.com

**Niedersachsen, Nordrhein-
Westfalen, Rheinland-Pfalz, Schles-
wig-Holstein, Hamburg, Bremen**

INGUN Prüfmittelbau GmbH
Vertriebsbüro Nord
Hans-Jürgen Göbel
Glück-Auf-Straße 22
D-31655 Stadthagen
Tel. +49 5721 72720
Fax +49 5721 77502
hans-juergen.goebel@ingun.com

**Sachsen, Sachsen-Anhalt,
Thüringen, Berlin, Brandenburg,
Mecklenburg-Vorpommern**

K.-W. Thomas Richter
Automation
Nelkengrund 10
D-39130 Magdeburg
Tel. +49 391 7331827
Fax +49 391 7331827
thomas.richter@ingun.com

Europe

Benelux
Bosnien-Herzegowina
Dänemark
Estland
Finnland
Frankreich
Großbritannien
Italien
Kroatien
Norwegen
Österreich
Polen
Portugal
Rumänien
Schweden
Schweiz
Serbien
Slowakei
Slowenien
Spanien
Tschechische Republik
Türkei
Ungarn

Asia

China
Hongkong
Indien
Japan
Korea
Malaysia
Taiwan
Thailand
Vietnam

Africa

Südafrika

Australia

Australien
Neuseeland

America

Argentinien
Brasilien
Kanada
Mexiko
USA

Die vollständigen
Adressen unserer
Auslandsvertretungen
finden Sie unter
www.ingun.com

*The addresses of the Inter-
national Agencies can be
found under
www.ingun.com*

ingun[®]

ingun Prüfmittelbau GmbH

Max-Stromeyer-Straße 162
78467 Konstanz

Germany

Tel. +49 7531 8105-0

Fax +49 7531 8105-65

info@ingun.com

www.ingun.com